

TANDY®

Direct Connect Modem Pak

OPERATION MANUAL

CAT. NO. 26-2228



The FCC Wants You to Know

This equipment generates and uses radio frequency energy. If not installed and used properly, that is in strict accordance with the manufacturer's instructions, it may cause interference to radio and television reception.

It has been type tested and found to comply with the limits for a Class B computing device in accordance with the specifications in Subpart J of Part 15 of FCC Rules which are designed to provide reasonable protection against such interference in a residential installation. However, there is no guarantee that interference will not occur in a particular installation.

If this equipment does cause interference to radio or television reception, which can be determined by turning the equipment off and on, the user is encouraged to try to correct the interference by one or more of the following measures:

- Reorient the receiving antenna
- Relocate the computer with respect to the receiver
- Move the computer away from the receiver
- Plug the computer into a different outlet so that computer and receiver are on different branch circuits.

If necessary, you should consult the dealer or an experienced radio television technician for additional suggestions. You may find the following booklet prepared by the Federal Communications Commission helpful. *How to Identify and Resolve Radio-TV Interference Problems*

This booklet is available from the US Government Printing Office, Washington, DC 20402, Stock No. 004-000-00345-4.

Warning

This equipment has been certified to comply with the limits for a Class B computing device, pursuant to Subpart J of Part 15 of FCC Rules. Only peripherals (computer input output devices, terminals, printers, etc.) certified to comply with the Class B limits may be attached to this computer. Operation with non-certified peripherals is likely to result in interference to radio and TV reception.

TERMS AND CONDITIONS OF SALE AND LICENSE OF TANDY COMPUTER EQUIPMENT AND SOFTWARE
PURCHASED FROM RADIO SHACK COMPANY-OWNED COMPUTER CENTERS, RETAIL STORES AND
RADIO SHACK FRANCHISEES OR DEALERS AT THEIR AUTHORIZED LOCATIONS

LIMITED WARRANTY

I. CUSTOMER OBLIGATIONS

- A. CUSTOMER assumes full responsibility that this computer hardware purchased (the "Equipment"), and any copies of software included with the Equipment or licensed separately (the "Software") meets the specifications, capacity, capabilities, versatility, and other requirements of CUSTOMER.
- B. CUSTOMER assumes full responsibility for the condition and effectiveness of the operating environment in which the Equipment and Software are to function, and for its installation.

II. LIMITED WARRANTIES AND CONDITIONS OF SALE

- A. For a period of ninety (90) calendar days from the date of the Radio Shack sales document received upon purchase of the Equipment RADIO SHACK warrants to the original CUSTOMER that the Equipment and the medium upon which the Software is stored is free from manufacturing defects. **This warranty is only applicable to purchases of Tandy Equipment by the original customer from Radio Shack company-owned computer centers, retail stores, and Radio Shack franchisees and dealers at their authorized locations.** The warranty is void if the Equipment's case or cabinet has been opened, or if the Equipment or Software has been subjected to improper or abnormal use. If a manufacturing defect is discovered during the stated warranty period, the defective Equipment must be returned to a Radio Shack Computer Center, a Radio Shack retail store, a participating Radio Shack franchisee or a participating Radio Shack dealer for repair, along with a copy of the sales document or lease agreement. The original CUSTOMER'S sole and exclusive remedy in the event of a defect is limited to the correction of the defect by repair, replacement, or refund of the purchase price, at RADIO SHACK'S election and sole expense. RADIO SHACK has no obligation to replace or repair expendable items.
- B. RADIO SHACK makes no warranty as to the design, capability, capacity, or suitability for use of the Software, except as provided in this paragraph. Software is licensed on an "AS IS" basis, without warranty. The original CUSTOMER'S exclusive remedy, in the event of a Software manufacturing defect, is its repair or replacement within thirty (30) calendar days of the date of the Radio Shack sales document received upon license of the Software. The defective Software shall be returned to a Radio Shack Computer Center, a Radio Shack retail store, a participating Radio Shack franchisee or Radio Shack dealer along with the sales document.
- C. Except as provided herein no employee, agent, franchisee, dealer or other person is authorized to give any warranties of any nature on behalf of RADIO SHACK.
- D. **EXCEPT AS PROVIDED HEREIN, RADIO SHACK MAKES NO EXPRESS WARRANTIES, AND ANY IMPLIED WARRANTY OF MERCHANTABILITY OR FITNESS FOR A PARTICULAR PURPOSE IS LIMITED IN ITS DURATION TO THE DURATION OF THE WRITTEN LIMITED WARRANTIES SET FORTH HEREIN.**
- E. Some states do not allow limitations on how long an implied warranty lasts, so the above limitation(s) may not apply to CUSTOMER.

III. LIMITATION OF LIABILITY

- A. **EXCEPT AS PROVIDED HEREIN, RADIO SHACK SHALL HAVE NO LIABILITY OR RESPONSIBILITY TO CUSTOMER OR ANY OTHER PERSON OR ENTITY WITH RESPECT TO ANY LIABILITY, LOSS OR DAMAGE CAUSED OR ALLEGED TO BE CAUSED DIRECTLY OR INDIRECTLY BY "EQUIPMENT" OR "SOFTWARE" SOLO, LEASED, LICENSED OR FURNISHED BY RADIO SHACK, INCLUDING, BUT NOT LIMITED TO, ANY INTERRUPTION OF SERVICE, LOSS OF BUSINESS OR ANTICIPATORY PROFITS OR CONSEQUENTIAL DAMAGES RESULTING FROM THE USE OR OPERATION OF THE "EQUIPMENT" OR "SOFTWARE." IN NO EVENT SHALL RADIO SHACK BE LIABLE FOR LOSS OF PROFITS, OR ANY INDIRECT, SPECIAL, OR CONSEQUENTIAL DAMAGES ARISING OUT OF ANY BREACH OF THIS WARRANTY OR IN ANY MANNER ARISING OUT OF OR CONNECTED WITH THE SALE, LEASE, LICENSE, USE OR ANTICIPATED USE OF THE "EQUIPMENT" OR "SOFTWARE."**
NOTWITHSTANDING THE ABOVE LIMITATIONS AND WARRANTIES, RADIO SHACK'S LIABILITY HEREUNDER FOR DAMAGES INCURRED BY CUSTOMER OR OTHERS SHALL NOT EXCEED THE AMOUNT PAID BY CUSTOMER FOR THE PARTICULAR "EQUIPMENT" OR "SOFTWARE" INVOLVED.
- B. RADIO SHACK shall not be liable for any damages caused by delay in delivering or furnishing Equipment and/or Software.
- C. No action arising out of any claimed breach of this Warranty or transactions under this Warranty may be brought more than two (2) years after the cause of action has accrued or more than four (4) years after the date of the Radio Shack sales document for the Equipment or Software, whichever first occurs.
- D. Some states do not allow the limitation or exclusion of incidental or consequential damages, so the above limitation(s) or exclusion(s) may not apply to CUSTOMER.

IV. SOFTWARE LICENSE

RADIO SHACK grants to CUSTOMER a non-exclusive, paid-up license to use the TANDY Software on one computer, subject to the following provisions:

- A. Except as otherwise provided in this Software License, applicable copyright laws shall apply to the Software.
- B. Title to the medium on which the Software is recorded (cassette and/or diskette) or stored (ROM) is transferred to CUSTOMER, but not title to the Software.
- C. CUSTOMER may use Software on one host computer and access that Software through one or more terminals if the Software permits this function.
- D. CUSTOMER shall not use, make, manufacture, or reproduce copies of Software except for use on one computer and as is specifically provided in this Software License. Customer is expressly prohibited from disassembling the Software.
- E. CUSTOMER is permitted to make additional copies of the Software only for backup or archival purposes or if additional copies are required in the operation of one computer with the Software, but only to the extent the Software allows a backup copy to be made. However, for TRSDOS Software, CUSTOMER is permitted to make a limited number of additional copies for CUSTOMER'S own use.
- F. CUSTOMER may resell or distribute unmodified copies of the Software provided CUSTOMER has purchased one copy of the Software for each one sold or distributed. The provisions of this Software License shall also be applicable to third parties receiving copies of the Software from CUSTOMER.
- G. All copyright notices shall be retained on all copies of the Software.

V. APPLICABILITY OF WARRANTY

- A. The terms and conditions of this Warranty are applicable as between RADIO SHACK and CUSTOMER to either a sale of the Equipment and/or Software License to CUSTOMER or to a transaction whereby Radio Shack sells or conveys such Equipment to a third party for lease to CUSTOMER.
- B. The limitations of liability and Warranty provisions herein shall inure to the benefit of RADIO SHACK, the author, owner and/or licensor of the Software and any manufacturer of the Equipment sold by Radio Shack.

VI. STATE LAW RIGHTS

The warranties granted herein give the original CUSTOMER specific legal rights, and the original CUSTOMER may have other rights which vary from state to state.

Important Note

Your Modem Pak has been designed and constructed to conform to federal regulations and can be connected to the phone line as described in this manual.

Please note that each product connected to the telephone line places a certain load on the line. We designate this as the unit's "Ringer Equivalence Number."

When using more than one product on the line, total all the ringer equivalence numbers. If they total more than 5, your phone may not ring. In rural areas a total of 3 may impair ringer operation. To be sure, check with your local telephone company.

The registration number as well as ringer equivalence number appears on the bottom of the unit.

The Modem Pak must not be connected to:

- Coin-operated phones
- Party-line phones

IMPORTANT INFORMATION

It is very unlikely . . . but if your Modem Pak causes problems on the phone line, the telephone company has the right to temporarily discontinue your service. If this happens, the telephone company will notify you and give you a chance to have the problem corrected. Also, the telephone company has the right to make changes in their lines and/or equipment. If these changes affect your Modem Pak or require changes in its connection, the phone company will notify you in writing so you can take the necessary steps to insure uninterrupted service.

Direct Connect Modem Pak Operation Manual

© 1985 Tandy Corporation, Fort Worth, Texas 76102 U.S.A.

All Rights Reserved.

Reproduction or use, without express written permission from Tandy Corporation, of any portion of this manual is prohibited. While reasonable efforts have been taken in the preparation of this manual to assure its accuracy, Tandy Corporation assumes no liability resulting from any errors or omissions in this manual, or from the use of the information contained herein.

Contents

Introduction	1
1 Description of the Modem Pak	3
2 Installation	5
3 How to use your Modem Pak	9
4 Sample log-on session	21
5 Special character codes	23
6 Technical information	25
7 Programming examples	29
8 Troubleshooting and maintenance	33
9 Specifications	35
10 Schematic diagram	37

Introduction

Tandy's Direct Connect Modem Pak opens the door to the world of telecommunications. This 300-baud Modem Pak allows you to send and receive programs, but you can also use it to contact information services.

The DC Modem Pak is easy to use because it is designed to plug directly into the cartridge slot on the right side of your Color Computer, or into the Multi-Pak Interface (26-3124).

Special features include:

- Selectable word size, parity, and stop bit.
- Full- or half-duplex capability.
- True upper- and lowercase capability (only with these Color Computers: 26-3127B, 3134B or 3136B).
- A cassette recorder and printer can be operated without going back into BASIC mode.
- Special codes can be generated to edit transmit data and to create OS-9 characters.

To use the Modem Pak, you'll need a:

- Tandy Color Computer with at least 16K of RAM.
- Color TV (such as Radio Shack Cat. No. 16-232).
- Telephone.
- Cassette recorder. To transmit a previously written BASIC program or data, you'll need to load the program into the Color Computer's memory from a cassette recorder, such as Tandy's CCR-81 (26-1208) or CCR-82 (26-1209).
- Serial printer. You can print out received information while host-to-computer communication is in progress. Use a serial interface printer that is compatible with your Color Computer. Radio Shack has a line of Color-Computer-compatible serial printers, from the Thermal Printer TP-10 (26-1261) to the Daisy Wheel Printer DWP-220 (26-1278).

Description of the Modem Pak 1

- ① **Carrier detect indicator.** This indicator lights while the Modem Pak is receiving a carrier tone.
- ② **Line ON indicator.** This indicator lights when the Modem Pak is connected to the telephone line and the CONNECT switch is pressed to the ON position.
- ③ **CONNECT switch.** This switch connects the Modem Pak to the telephone line. Press this switch to transmit or receive data from the telephone line.
- ④ **ANSWER/ORIGINATE switch.** Slide this switch to the ANSWER position to set the Modem Pak to answer mode. Slide it to the ORIGINATE position to set the Modem Pak to originate mode.
- ⑤ **PHONE jack.** Connect to a duplex jack using modular-to-modular cable. For further information, refer to the **Installation** section of this manual.



Figure 1

Installation 2

Before connecting:

1. Be sure that all the equipment, including your Color Computer, is OFF.
2. Check to see that the CONNECT switch on the Modem Pak is set to the OFF (outward) position.
3. Connect the television to the Color Computer as described in the *Color Computer Operation Manual* or *Introducing YOUR COLOR COMPUTER 2*.

Connecting the Modem Pak to a Color Computer

Insert the Modem Pak into the cartridge slot on the right side of the Color Computer or into slot 1, 2 or 3 of the Multi-Pak Interface. Set the selector switch of the Multi-Pak Interface to the slot number in which the Modem Pak is inserted. (Slot 4 of the Multi-Pak Interface is usually used for the disk controller.)

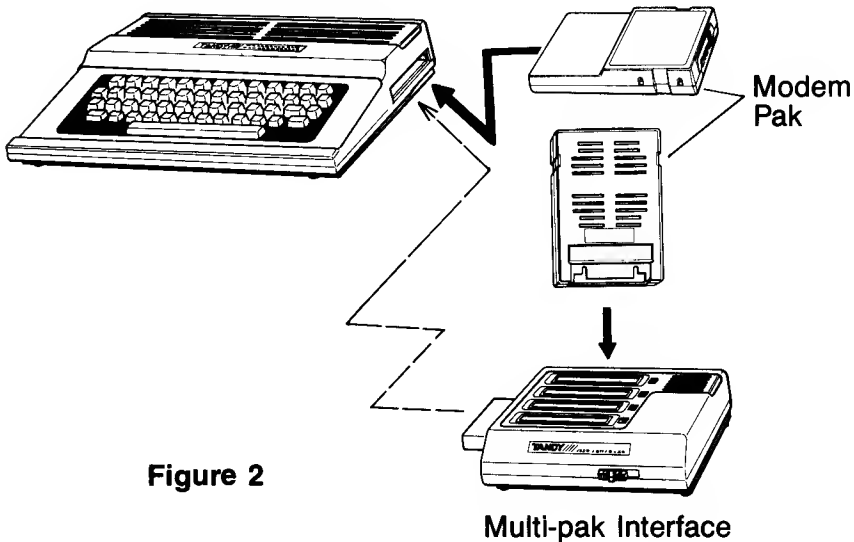

Figure 2

Connecting to a telephone

Disconnect your telephone cord from the wall plate and connect it to a duplex jack (279-357). To connect the Modem Pak to the telephone line, use a modular-to-modular cable (279-374). Insert one end of the cable into the PHONE jack on the Modem Pak, and the other end into the duplex jack as shown in Figure 3.

Notes:

1. With the Modem Pak connected, your phone can only be used for conversation when the CONNECT switch is off. So, be sure to set this switch to the off (outward) position when you are not using the Modem Pak.
2. Do not connect the duplex jack directly to the Modem Pak PHONE jack. The duplex jack has to be connected to the modular wall outlet as illustrated.

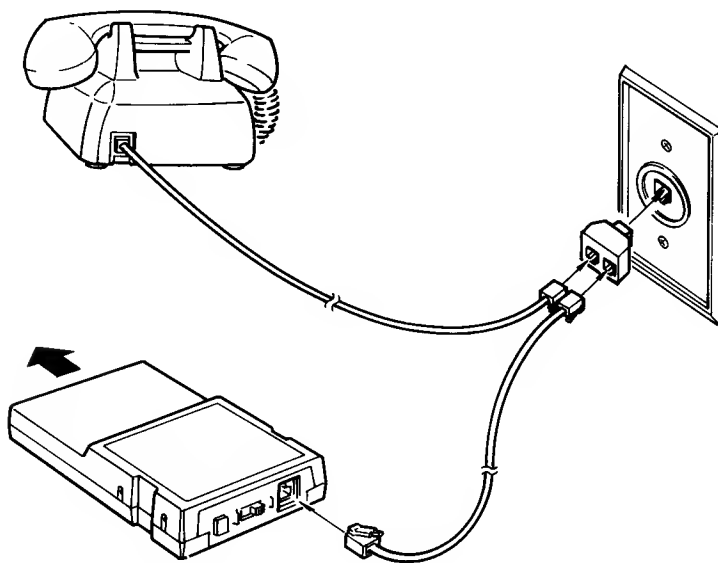

Figure 3

Connecting a cassette recorder

To transmit a previously written BASIC program or data, you will need to load the program into the Color Computer's memory from a cassette recorder.

1. Connect the short cable (DIN plug on one end and three plugs on the other) to the CASSETTE jack on the back of the Color Computer.
2. The three plugs on the other end of this cable are for connecting to the recorder. Consult your *Color Computer Operation Manual* or *Introducing YOUR COLOR COMPUTER 2*, and the cassette recorder owner's manual for instructions on connecting these three plugs to a cassette recorder.

Connecting a printer

To connect the Color Computer to a printer, you will need a 4-Pin DIN to 4-Pin DIN cable (26-3020).

1. Connect one end of the cable to the serial I/O connector on the rear side of the computer.
2. Connect the other end of the cable to the printer.
3. Consult your printer owner's manual for operating instructions.

Note: To avoid losing characters, printers may need an additional time delay after receiving a carriage return. If you have excessive characters on your print-outs, see your information/time-sharing service to obtain the proper configurations (see **Printer time adjustment** on page 13).

How to use your Modem Pak

Follow these procedures to power-up your system:

1. Turn the color computer and the television ON. The OK prompt should appear on the screen. If OK does not appear, press RESET.
2. Once the OK prompt is displayed, type:

EXEC &HC000 (ENTER)

or

EXEC 49152 (ENTER)

The copyright information and version number will be displayed. About 5 seconds after the copyright screen appears, the first page of the menu will be displayed (Figure 4). The second page of the menu can be displayed by pressing the (SPACE BAR) (Figure 5).

Upon power-up, the menu will always show the default settings as illustrated. The default or selected options are shown in reverse color (green with a black background).

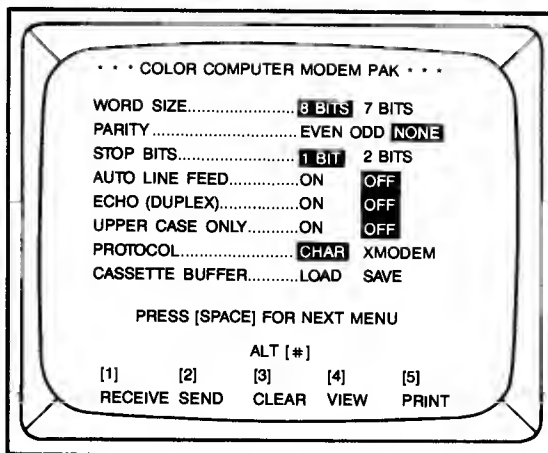

Figure 4

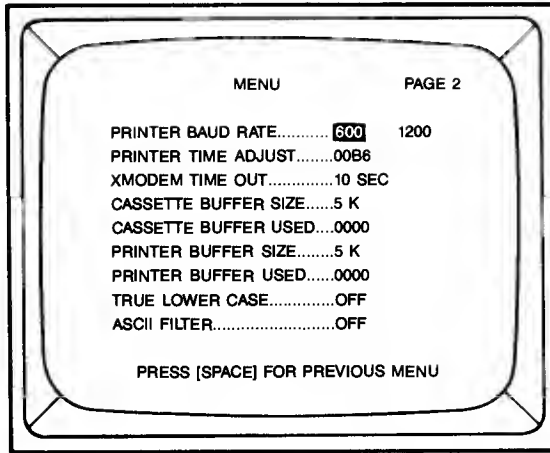

Figure 5

Changing communications settings

To change one of the communications parameters, move the cursor with the arrow keys (**↑** **↓** **→** **←**) and press **ENTER** ; or, after pressing **ENTER** , enter a new value with the up or down arrow keys (**↑** **↓**). To display the second page when you are viewing the first page, or vice versa, just press the **SPACE BAR** . To enter and leave terminal mode from the first page of the menu, press **BREAK** . To enter terminal mode from the second page of the menu, press **BREAK** twice.

***** The first page of the protocol menu *****

Word size (8 bits or 7 bits)

Select the length of a data word here. To change the option, move the cursor to the appropriate position with the left or right arrow keys (**←**) and press **ENTER** . Select another parameter by pressing the down arrow key (**↓**), or press **BREAK** to enter terminal mode.

Parity (even, odd or none)

To detect errors in transmit and receive data, select the parity from the options given by moving the cursor and pressing **ENTER** .

Stop bits (1 bit or 2 bits)

Move the cursor and press **ENTER** to change the number of stop bits; select either 1 or 2.

Auto line feed (ON or OFF)

This option lets you select whether the carriage return will be interpreted on the display as a carriage return and line feed combination (auto line feed: ON), or as a carriage return only (auto line feed: OFF). To set the auto line feed to on, move the cursor to ON and press **ENTER** . To set it to off, move the cursor to OFF and press **ENTER** .

Echo (ON or OFF)

Your options are either full-duplex (for simultaneous two-way communication) or half-duplex (for one-way communication). To change the setting, move the cursor with the left or right arrow keys and press **ENTER** . You may find that the data input by another person is echoed on your screen, but your own input data is not echoed when this parameter is set to OFF.

Uppercase only (ON or OFF)

This option allows you to communicate in either uppercase only (ON), or upper- and lowercase (OFF). To change the setting, move the cursor with the left or right arrow keys and press **ENTER**. Although the characters do not appear on the display in true upper- and lowercase (lowercase is displayed in reverse color — see the section **True lowercase** for exception), the letters output to the printer are, in fact, upper- and lowercase letters.

Note: In the upper/lowercase mode, use **CLEAR** **0** to switch between uppercase only and upper/lowercase.

Protocol (CHAR or XMODEM)

Select CHAR (character code) when transmitting ASCII character code only. When transmitting data that contains graphic codes or data that is in binary (such as a machine language program), select XMODEM. To communicate with a different type of computer, use XMODEM to avoid transmission errors. In XMODEM mode, data is divided into blocks of 128 bytes and transmitted with the checksum of that data block. Because of this block format, control characters contained in data are considered to be part of the data, and are transmitted with no individual check. Thus, binary data can also be transmitted. The communications protocol should be 8-bit, no parity with one stop bit. To change the setting, move the cursor with the left or right arrow keys and press **ENTER**.

Note: The remote computer system must use the same protocol that you select.

Cassette buffer (Load or Save)

With this option, you can load a program or data stored on cassette tape, or save to tape the program already stored in the cassette buffer.

To load a program, set the tape recorder to play mode, position the cursor to **LOAD** and press **ENTER**. After the **FILENAME :** prompt appears on the screen, input the file name and press **ENTER**. The cursor stops blinking until the program is fully loaded.

If you had a cassette I/O error message, check the computer-cassette recorder connection or volume setting of your cassette recorder, and try once again.

To save a program or data stored in the cassette buffer, set the tape recorder to record mode. Move the cursor to `SAVE` and press `(ENTER)`. When the file name prompt appears, input the file name and press `(ENTER)`. The cursor starts blinking after the program is completely saved on cassette.

Notes:

- A file name can be a maximum of eight characters in length.
- To stop the loading or saving of data, press and hold the `(BREAK)` key. If the loading/saving process doesn't stop, try pressing the `RESET` switch on the back of your computer.

***** The second page of the protocol menu *****

Look at the second page of the protocol menu before going into terminal mode. As you may recall, all you need to do is press the `(SPACE BAR)` to display the second page of the menu screen.

Printer baud rate (600 or 1200)

Set the baud rate of your printer to that of the computer. The Color Computer's default baud rate is set at 600 for line printers. Select 600 or 1200 with the left or right arrow keys and press `(ENTER)`.

Printer time adjustment

Basically, the output timing of a printer is set to B6 at 600 baud, and 5B at 1200 baud. If your printer happens to have errors, change this printer time with the up or down arrow keys after pressing `(ENTER)`.

For example, if you are using a DWP-210 (26-1257), you need to set the time that is in the range of A7-BB at 600 baud, and in the range of 50-5A at 1200 baud.

XMODEM Time Out (10 sec to 60 sec)

Selects the XMODEM time-out counter (time needed to perform the checksum verification). Press the up or down arrow keys after pressing **(ENTER)** to match your time-out counter with that of the remote computer; this allows proper handshaking to occur.

Cassette buffer size

The memory size of the cassette buffer is set to 5K at initialization. It can be increased or decreased by pressing the up or down arrow keys after **(ENTER)** is pressed.

Note: When the cassette buffer is almost full, the message `CASSETTE BUFFER ALMOST FULL` will appear on the screen to alert you to this condition. When this happens, follow the appropriate procedure to stop the remote system from transmitting data. (Refer to your host computer documentation for details.)

Cassette buffer used

Indicates how much cassette buffer space has been used. This lets you know the available buffer size left for new data.

Printer buffer size

The memory size of the printer buffer is set to 5K at initialization. Be sure to set aside enough buffer space, especially when you are using large files or when printing on a low-speed printer. To change the buffer size, first press **(ENTER)**, then increase or decrease the size with the up or down arrow keys.

Note: The total buffer size (cassette buffer + printer buffer) can be up to 28K with a computer that has 64K RAM. With a 16K RAM computer, the total buffer size is limited to 12K. Before transferring your data file, be sure that there is enough space available for it in the printer buffer. When using the modem pak with any Tandy printer, the printer buffer should never overflow unless the printer is off-line when you attempt to transfer data.

Printer buffer used

Indicates the amount of printer buffer used. This lets you know how much buffer space is available for new data.

Note: During an XMODEM transfer, the print function is not supported and so the printer buffer is not used. This allows the Modem Pak to access the full buffer area for the cassette buffer during these operations. No matter what size cassette buffer you have allocated, the full buffer area will be used in the XMODEM mode. Also note that during an XMODEM transfer, data is not added to the end of the buffer, but replaces what has already been stored in the buffer. In the character mode, data is added to the end of the buffer.

True lowercase (ON or OFF)

To display the true (not color reverse lowercase letters noted in the section called **Uppercase only**) lowercase letters, set this parameter to ON. You can change the OFF condition to ON by pressing **ENTER**. To change ON to OFF, press **ENTER** once again.

Note: The true lowercase mode will work only with Color Computers that have one of the following catalog numbers: 26-3134B, 26-3136B or 26-3127B.

ASCII filter (ON or OFF)

To transmit ASCII codes only (7-bit codes only), set this to ON. All characters over 80 hex, and any control codes except BKSP, HT, LF, CR and ESC, are filtered out. To transmit data that contains graphic codes or special key codes, set this to OFF. You can change the ON/OFF condition by pressing **ENTER**.

Now, you've got all the necessary information about the Modem Pak menu. Press **BREAK** or the **SPACE BAR** to return to the first menu, or press **BREAK** twice to enter the terminal mode to begin communications.

TERMINAL MODE

By entering this mode, you can use your Color Computer as an interactive terminal with a host system. Most information services can be contacted via this mode.

ALT function keys

While you are in the communications (terminal) mode, you can use the following ALT [#] key functions. The number of each ALT key and its summarized description are listed at the bottom of the first page of the protocol menu.

- @ ① ... Close or open the cassette buffer for storing data. Press @ and ① simultaneously. The message CASSETTE BUFFER OPEN FOR RECEIVE indicates the data you input (with ECHO ON), and data from the host can be stored in the cassette buffer. To close the buffer, press @ ① again. CASSETTE BUFFER CLOSED is displayed.

In the XMODEM mode, the message RECEIVING XMODEM FILE appears when you press @ and ①. The Modem does not execute any command except **BREAK** until the Modem receives data from the transmitter. For each block of data that is received or sent, XMODEM protocol will display a dot on the screen. When the communication is over, the cassette buffer closes and the Modem returns to the terminal mode automatically.

- @ ② ... Send the data in the cassette buffer. Press @ and ② simultaneously. The message SENDING CASSETTE BUFFER will appear on the screen and the data in your cassette buffer will be sent to the host computer automatically. When all the data has been sent, the message TRANSMISSION COMPLETE will appear on the display.

Note: Since you cannot send data in the cassette buffer while the cassette buffer is open, be sure to close it as indicated in the preceding ALT function key description.

- @ ③ ... Clear the cassette buffer. You can clear all data in the cassette buffer by pressing @ and ③ at the same time.
- @ ④ ... View the cassette buffer. To check the data in the cassette buffer, press @ and ④ simultaneously.
- @ ⑤ ... Press @ and ⑤ simultaneously to open the printer buffer and set the printer to ON. The message PRINTER FUNCTION ON will appear and you can make a hard copy of the data displayed on the screen (the data transmitted with ECHO:OFF cannot be printed). To close the printer buffer, press @ ⑤ again. The message PRINTER FUNCTION OFF tells you that the printer buffer is closed.

Note: The ALT function keys 3 (CLEAR) and 4 (VIEW) are available from the main menu, as well as in terminal mode. Both of these keys will operate the same in either mode. The ALT function key 5 (PRINT) is also available from the main menu, but its function, when selected from the main menu, is somewhat different from its operation in terminal mode. When it is selected from the main menu, the entire contents of the cassette buffer is printed out. (This operation can be cancelled by pressing **BREAK** .)

Loading BASIC program/data files into the cassette buffer

Important: The BASIC programs to be loaded/stored in the cassette buffer of the Modem Pak must be in ASCII format. Use `CSAVE filename , A` to store on tape.

1. Power-up the system, making sure the cassette recorder is properly connected to the Color Computer. Push the PLAY button down until it locks.
2. Input `EXEC &HC0000` or `EXEC 49152` and press **ENTER** . The first page of the protocol menu is displayed on the screen. If you would like to adjust the cassette buffer size, press the **SPACE BAR** to display the second page of the protocol menu.

- Then move the cursor to the fourth line of the menu, CASSETTE BUFFER SIZE, and press **(ENTER)**. After changing the buffer size with the up or down arrow keys, return to the first page by pressing the **(SPACE BAR)** or **(BREAK)**.
3. Move the cursor to the eighth line of the menu, CASSETTE BUFFER..LOAD SAVE, with the down arrow key. While the cursor is on the word LOAD, press **(ENTER)**.
 4. The FILENAME: prompt appears. Input the file name and press **(ENTER)**.
 5. The tape recorder starts and the program is loaded to the cassette buffer. To stop the loading or saving of data, press and hold the **(BREAK)** key. If the loading/saving process doesn't stop, try pressing the RESET switch on the back of your computer.
 6. To check the data written to the cassette buffer, press **@ 4** simultaneously.

Storing BASIC program/data files into the cassette buffer

1. Before communication can take place, you need to enter terminal mode. Open the cassette buffer with the **@ 1** keys as described under the heading **ALT function keys**.
2. Use **@ 4** to check the cassette buffer or **@ 3** to clear it, if necessary.
3. Dial the host's telephone number. When the phone is answered, you hear a high-pitched tone. Press the CONNECT switch (to the ON position) and gently hang up the phone.
4. As long as the cassette buffer is open, all the data received from the host will be stored in the buffer. While the ECHO mode is ON, the data from your own keyboard can also be stored in the buffer.
5. Be sure to close the buffer after storing data by pressing **@ 1** once again.

Saving BASIC program/data files stored in the cassette buffer

1. Insert a blank cassette into the cassette recorder. Press the recorder's PLAY and RECORD buttons at the same time until they lock.
2. If you are in terminal mode, return to the protocol menu by pressing **BREAK** .
3. Move the cursor to the word SAVE on the eighth line of the menu, CASSETTE BUFFER..LOAD SAVE, with the down and right arrow keys, and press **ENTER** .
4. The FILENAME : prompt appears. Input the file name and press **ENTER** .

Note: BASIC programs are stored in ASCII format.

Transmitting BASIC program/data files stored in the cassette buffer

1. Load a file from the cassette recorder as described on page 17. Check to be sure the cassette buffer is closed.
2. Set up for communication as described in step 3 at lower section on the previous page.
3. Press **@** **2** simultaneously. The file will be sent to the host computer automatically. If the ECHO mode is ON and you are in character protocol, you will see the file being displayed on the screen as it is being transmitted.

Attention OS-9 users . . .

Version 02.00.00 or greater of OS-9 contains the M1 and M2 drivers. These drivers can be installed with the Config Utility. The M1 driver requires that the Modem Pak be inserted into slot 1 of the Multi-Pak Interface because it utilizes a hardware interrupt. The M2 driver, on the other hand, can be used in any slot except slot 1 because it uses a polled software interrupt. (Consult your OS-9 manual for complete details.)

Sample log-on session **4**

Before establishing communications, be sure to match the communication protocols with your host.

Originating a call

1. Power-up the system. Be sure all peripherals are properly connected.
2. Type EXEC &HC000 (ENTER) or EXEC 49152 (ENTER) to display the protocol menu.
3. When the protocol menu appears, check the default settings and make sure that your settings agree with those of your host. If you want to send the program stored on cassette, load the program into the cassette buffer in advance by using the CASSETTE BUFFER.. LOAD parameter. After making the necessary preparations at the protocol menu, enter terminal mode by pressing (BREAK) .
4. Before placing a call, you can open the cassette or printer buffer to store the data into the cassette buffer, or to print out the data by using the ALT function keys.
5. Set the ANSWER/ORIGINATE switch to the ORIGINATE position (the host computer should be in ANSWER mode).
6. With the CONNECT switch off (out), dial the telephone number of the host computer.
7. When you hear the carrier tone, press in the CONNECT switch (ON) and hang up the phone.
8. When the carrier detect (CD) indicator lights, you can begin communicating. If you should decide to change any of the parameters on the protocol menu while this exchange of information is in progress, you can do so without interrupting communications. All you need to do is press (BREAK) to re-enter the protocol menu. Make any necessary changes, and then press (BREAK) again to return to terminal mode. When communication is finished, be sure to sign off. (The sign-off will depend on the host computer; however, BYE or GOODBYE is commonly used.)
9. After signing off, wait until the carrier detect LED (CD) goes off; then press the CONNECT switch so that it returns to the off (out) position.

Answering a call

1. Set the ANSWER/ORIGINATE switch to the ANSWER position.
2. Wait for the remote computer operator to call you.
3. Upon receiving the call, press in the CONNECT switch (ON), and hang up the phone.
4. When the carrier detect (CD) indicator lights, begin data communications.
5. When finished with the data transfer, press the CONNECT switch so that it returns to the off (out) position.

Special character codes 5

Screen control codes

In general, you can use the Color Computer keyboard as usual. However, while you are using the DC Modem Pak to transmit data, some keys can perform certain operations. The following table summarizes the special keyboard capabilities of the Color Computer when used with the Modem Pak.

CLEAR + **BREAK** ... function as **ESC**

Hex Value	Keyboard Entry	Operation
08	← or CLEAR H	Backspace cursor or erase character
09	→ or CLEAR I	Horizontal tab
0A	↓ or CLEAR J	Move cursor down one line
0C	↑ or CLEAR L	Clear the whole page and move the cursor to the home position
1B 41	CLEAR + BREAK A	Move cursor up one line
1B 42	CLEAR + BREAK B	Move cursor down one line
1B 43	CLEAR + BREAK C	Move cursor one space to the right
1B 44	CLEAR + BREAK D	Move cursor one space to the left
1B 48	CLEAR + BREAK H	Move cursor to the beginning of the page (HOME)
1B 4B	CLEAR + BREAK K	Clear data to end of line
1B 4A	CLEAR + BREAK J	Clear data to end of page
1B 6A	CLEAR + BREAK j	Clear the whole page and move the cursor to the home position
1B 59	CLEAR + BREAK Y	*Reposition cursor to designated
x y	x y	line (x) and column (y)

* This code indicates the location of the cursor by specifying in hexadecimal the *x* (line) and *y* (column) coordinates. Note, however, that the actual values given to the computer are *x minus 20 hex* and *y minus 20 hex*. For instance, assume that you assign "!" to *y* and "#" to *x*. The ASCII code for "!" is 21 hex and for "#" is 23 hex; by

Special character codes

subtracting 20 hex, the values become 1 and 3 respectively. Therefore, the cursor is located in column 1 on line 3.

To use the **ESC** control codes, follow these steps:

1. Press and hold **CLEAR** and add **BREAK** to it.
2. Release **BREAK** first, and then release **CLEAR**.
3. Press the appropriate alphabetic key. (These must be upper case or lower case, as indicated in the table above.)

Special characters

Special ASCII codes that are not displayed on the keyboard (such as those used in OS-9) can be generated by using **CLEAR** in combination with certain keys.

CLEAR ... functions as **CTRL**

Hex Value	OS-9 Character	Keyboard Entry	Display Character		Character on Printer
			(True Lowercase Mode: OFF)	(ON)	
5B	[CLEAR 8	[[[
5D]	CLEAR 9]]]
7B	{	CLEAR ,	{	{	{
7D	}	CLEAR .	}	}	}
5C	\	CLEAR /	\	\	\
7E	~	CLEAR 3	~	~	~
5E	^	CLEAR 7	^	^	^
7C		CLEAR 1			
60	,	CLEAR @	space	space	,
5F	_	CLEAR -	←	←	_
1B	ESC	CLEAR BREAK	escape	escape	none

Note: To generate the @ mark, you must press **SHIFT** together with @, since @ is used for the ALT key functions.

Description of 6551 ACIA

The following information will help you to write a machine-language program for yourself.

The heart of the Modem Pak is the 6551 ACIA (Asynchronous Communication Interface Adapter). It has an on-chip baud rate generator, programmable interrupts and status register for ease of operation, false start bit detection, and echo mode.

This ACIA board is memory mapped to addresses FF6C to FF6F (Hex). The 6551 uses four memory addresses for the following functions.

Address		Write	Read
Hex	Decimal		
FF6C	65388	Transmit Data Register	Receiver Data Register
FF6D	65389	Soft Reset	Status Register
FF6E	65390		Command Register
FF6F	65391		Control Register

This table shows that only the command and control registers are bi-directional. The soft reset operation clears the 6551 internal registers, but does not cause any data transfer. Therefore, the data written is "don't care." A RES* from the bus will clear all registers in the 6551, while a soft reset will disable interrupts and the transmitter, turn off the echo mode, and clear the overrun error flag only.

The following explains the status, command, and control registers and gives programming examples for each.

Status register

The status register is used to indicate to the processor the status of various 6551 functions.

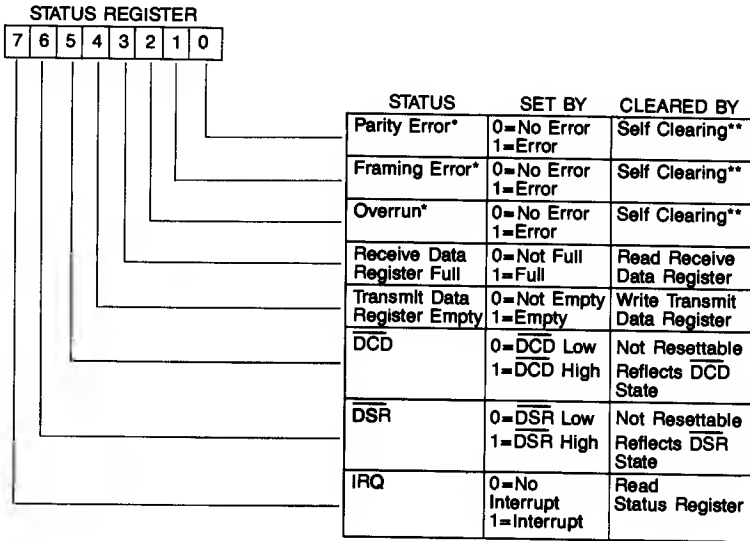

*NO INTERRUPT GENERATED FOR THESE CONDITIONS.
 **CLEARED AUTOMATICALLY AFTER A READ OF RDR AND THE NEXT ERROR FREE RECEIPT OF DATA.

	7	6	5	4	3	2	1	0
HARDWARE RESET	0	—	—	1	0	0	0	0
PROGRAM RESET	—	—	—	—	—	0	—	—

Command register

The command register is used to control specific transmit/receive functions.

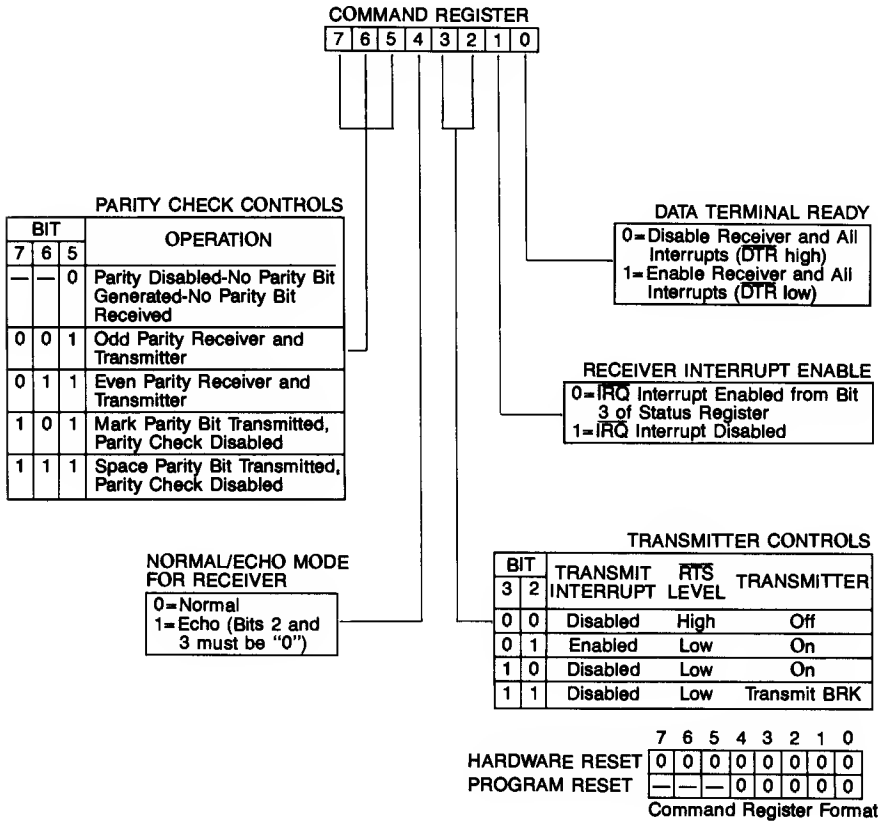

Control register

The control register is used to select the desired mode for the 6551. The word length, number of stop bits, and clock controls are all determined by the control register.

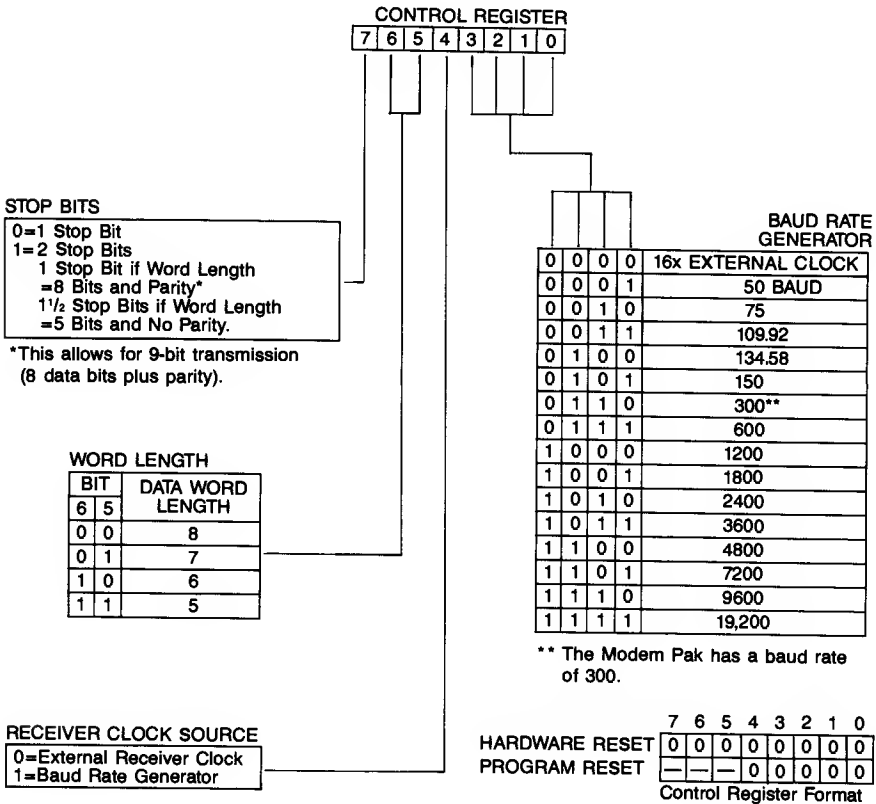

Programming examples 7

Machine Language

Desired configuration: baud rate = 300, word length = 7 bits, stop = 2 bits, parity = even

	Instructions		Comments
To program the Control Register			
	CLRA		
	ORA	# \$80	2 Stop Bits
	ORA	# \$20	7-Bit Word
	ORA	# \$10	Receiver Clock=Baud Rate Gen.
	ORA	# \$06	300 Baud Rate
	STA	\$FF6F	Write to Control Register
To program the Command Register			
	CLRA		
	ORA	# \$60	Even Parity
	ORA	# \$00	MODE=Normal
	ORA	# \$08	Tx. Int. Disabled, RTS Active Tx. On
	ORA	# \$02	IRQ Int. Disabled
	ORA	# \$01	Rx Enabled and All Int.
	STA	\$FF6E	Write to Command Register
To check the Modem Status (DSR)			
CKMDM	LDA	\$FF6E	Load Command Byte
	ORA	# \$01	Insure that DTR Bit is Active
	STA	\$FF6E	Output to Command Register
	LDA	\$FF6D	Read Status Register
	ANDA	# \$40	Check DSR Status
	BNE	CKMDM	Not Ready
	BRA	MREADY	Modem Is Ready (Power-Up)
To check the Carrier Status (DCD)			
	LDA	\$FF6D	Load Status Register
	ANDA	# \$20	Check DCD Status
	BNE	CAROFF	Carrier Is Not Present
	BRA	CARON	Carrier Is Present

Programming examples

Instructions			Comments
To transmit a data byte			
TXDT	LDA	\$FF6D	Check Tx-Register Status
	AND	#\$10	If Empty or Not
	BEQ	TXDT	Not Empty, Wait Tx Data
	LDA	DATA	Get Data Byte from RAM
	STA	\$FF6C	Write to Data Register
To receive a data byte			
RXDT	LDA	\$FF6D	Read Status Register
	TFR	A,B	Save Status
	AND	#\$08	Check if Received Any Data
	BEQ	RXDT	Not Received Yet
	ANDB	#\$07	Received, Check Any Error
	BEQ	RXDATA	No Error, Good Data
	LSRB		Error, Check Type of Error
	BCS	PARERR	Parity Error
	LSRB		Error, Check Type of Error
	BCS	FRAERR	Framing Error
	BRA	OVRERR	Overrun Error

Notes:

1. These example programs are applicable when interrupts are disabled.
2. To execute the above programs, you must have an assembler, such as EDTASM (26-3250) or Disk EDTASM (26-3254).

BASIC

Desired configuration: baud rate = 300, word length = 7 bits, stop = 2 bits, parity = even

Instructions	Comments
To program the Control Register	
10 X=182	This is B6 (HEX), 300 Baud, 7-bit Word, 2 Stop Bits
20 POKE 65391,X	Write to Control Register FF6F (HEX)
To program the Command Register	
30 Y=107	This is 6B (HEX), Even Parity, Normal Receive, Trans. Int. Disabled, RTS Active, IRQ Disabled, Receiver Enabled
40 POKE 65390,Y	Write to Command Register FF6E (HEX)
To check the Modem Status	
50 A=PEEK(65390)	Get Current Command Byte
60 A=A OR 1	OR in DTR Enable Bit
65 POKE 65390,A	Output New Command Byte
70 B=PEEK(65389)	Read Status
75 B=B AND 64	Check only DSR Status
80 IF B=0 THEN 100	If B=0, Modem Is Ready
90 PRINT "MODEM IS NOT READY"	If B > 0, Modem Is Not Ready
95 END	
100 PRINT "MODEM IS READY"	
To check the Carrier Status	
110 Z=PEEK(65389)	Read Status Register
120 Z=Z AND 32	Mask Off All but DCD Status
130 IF Z=0 THEN 160	If Z=0, then We Have Carrier; Otherwise, We Do Not
140 PRINT "NO CARRIER"	
150 END	
160 PRINT "GOT CARRIER!"	

Programming examples

Instructions		Comments
To transmit a data byte		
200	A=PEEK(65389)	FF6D (HEX)
210	A=A AND 16	Transmit Holding Register Empty?
220	IF A=0 THEN 200	Not Empty
230	POKE 65388,D	D Has Data Byte
To receive a data byte		
300	A=PEEK(65389)	Read Status Register
310	B=A AND 8	Receive Register Full?
320	IF B=0 THEN 300	No Data Yet
330	E=A AND 7	Check for Errors
340	IF E=0 THEN 400	No Errors
350	IF E=1 THEN 370	Parity Error
355	IF E=2 THEN 380	Framing Error
360	PRINT "OVERRUN ERROR!"	Must Be Overrun Error
365	END	
370	PRINT "PARITY ERROR!"	
375	END	
380	PRINT "FRAMING ERROR!"	
390	END	
400	D=PEEK(65388)	
410	PRINT "BYTE RECEIVED WAS";D	Got Data Byte in D

Troubleshooting and maintenance **8**

When something goes wrong

If you have trouble (garbled data, intermittent errors, etc.), check the following:

- The phone connection should be clean and noise-free.
- There should be no one talking on the telephone line.
- The phone and all extension phones should be on-hook.
- The baud rate should be 300.

Troubleshooting chart

Symptom	Problem/Solution
Carrier detect light off	Check telephone connections. Refer to Installation . The ANSWER/ORIGINATE switch is not in the proper position. Refer to the Sample Log-On Session . The modem at the other end is not compatible. The modem should be a Bell-system 103 or equivalent.
Garbled display	The phone is not on-hook. Hang up the phone. Communications protocol may be set incorrectly (baud rate, word length, parity, stop bit). Check and change, if necessary.

Care and maintenance

The most common cause of problems is a bad telephone connection. Noise on the line or a weak signal can result in lost or invalid data. Try to re-dial the call to insure that the connection is free of noise and interference.

The only maintenance your Modem Pak should require is a periodic check of the cartridge connection to the Color Computer and the connection to the telephone line. When you experience problems during data transfer, always check these connections. If you continue to have problems, contact your nearest Radio Shack Computer Center.

Lightning

Your Modem Pak has built-in protection circuits — that meet or exceed F.C.C. requirements — to reduce risk or damage from surges in telephone line current. However, an incident such as a lightning strike near, or directly to, these lines may cause an excessive surge of voltage that can damage the phone device.

Lightning damage is uncommon, but it can occur to phones and other electronic devices. If you are concerned about it or live in an area with frequent and/or severe electrical storms, we suggest that you unplug your electronic products during the storms.

Specifications 9

Dimensions

Length	6.2" (157 mm)
Width	4.3" (108 mm)

Environmentals

Temperature (Operating)	55°F — 85°F (12.8°C — 29.4°C)
Humidity (Operating)	40% to 80% non-condensing

Electrical performance specifications

Receive frequencies

Answer	Mark	1270 Hz
	Space	1070 Hz
Originate	Mark	2225 Hz
	Space	2025 Hz

Transmit frequencies

Answer	Mark	2225 Hz
	Space	2025 Hz
Originate	Mark	1270 Hz
	Space	1070 Hz

Transmit power

(Loop current at 40 mA) — 13 dBm

Receive sensitivity

(Loop current at 40 mA) — 35 dBm

Baud rate

300 BPS

Line DC resistance

200 ohm

(Loop current at 20 mA)

Current drain

120 mA

Cartridge connect signals

Pin No.	Signal Name	Description
1	NC	Not Connected
2	NC	Not Connected
3	HALT*	Halt Input to the CPU
4	NMI*	Non-Maskable Interrupt to the CPU
5	RESET*	Main Reset and Power-Up Clear Signal to the System
6	E	Main CPU Clock (0.89MHz)
7	Q	Quadrature Clock Signal which leads E
8	CART*	Interrupt Input for Cartridge Detection
9	+5V	+5V Volts (300 MA)
10	D0	CPU Data Bit 0
11	D1	CPU Data Bit 1
12	D2	CPU Data Bit 2
13	D3	CPU Data Bit 3
14	D4	CPU Data Bit 4
15	D5	CPU Data Bit 5
16	D6	CPU Data Bit 6
17	D7	CPU Data Bit 7
18	R/W*	CPU Read-Write Signal
19	A0	CPU Address Bit 0
20	A1	CPU Address Bit 1
21	A2	CPU Address Bit 2
22	A3	CPU Address Bit 3
23	A4	CPU Address Bit 4
24	A5	CPU Address Bit 5
25	A6	CPU Address Bit 6
26	A7	CPU Address Bit 7
27	A8	CPU Address Bit 8
28	A9	CPU Address Bit 9
29	A10	CPU Address Bit 10
30	A11	CPU Address Bit 11
31	A12	CPU Address Bit 12
32	CTS*	Cartridge Select Signal
33	GND	Signal Ground
34	GND	Signal Ground
35	SND	Sound Input
36	SCS*	Spare Select Signal
37	A13	CPU Address Bit 13
38	A14	CPU Address Bit 14
39	A15	CPU Address Bit 15
40	SLENB*	Input to Disable the Select

Schematic diagram 10

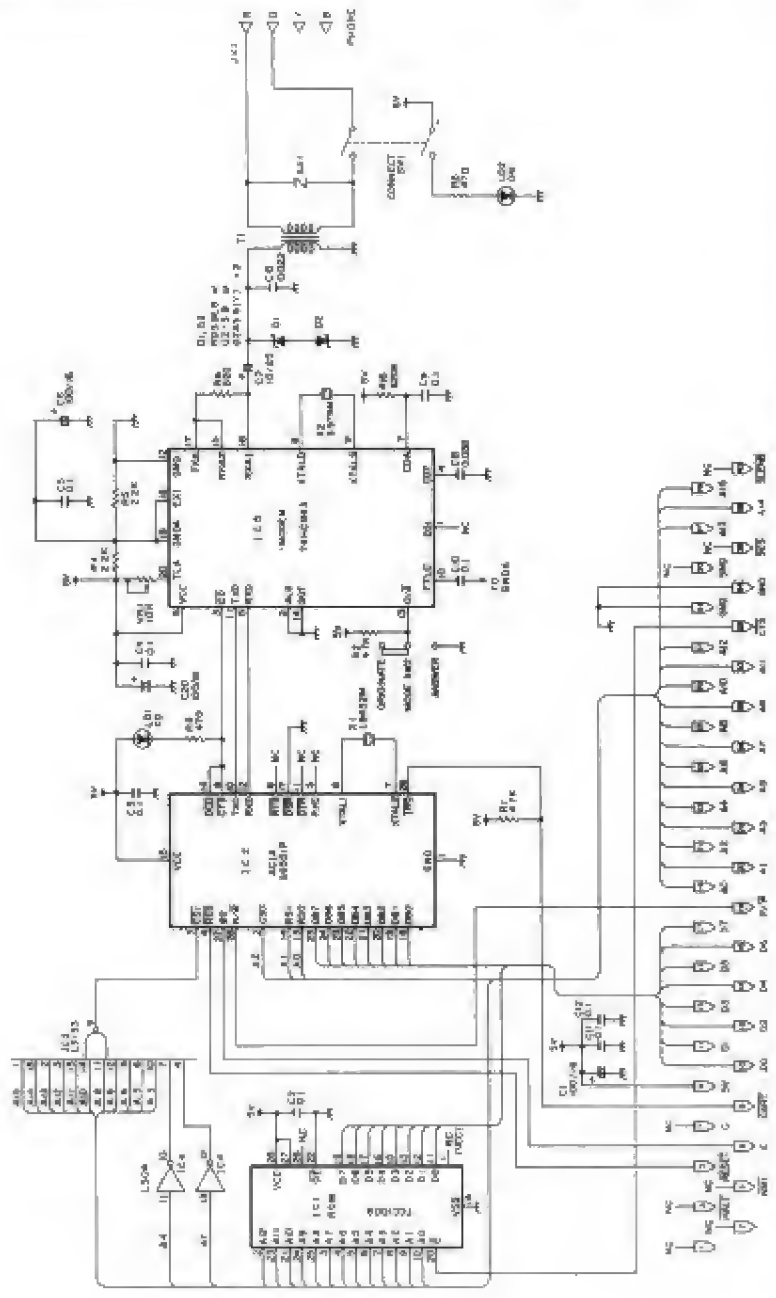

NOTE: (1) ALL RESISTANCE VALUES ARE INDICATED IN OHMS (E=10³ OHMS, M=10⁶ OHMS)
 (2) ALL CAPACITANCE VALUES ARE INDICATED IN PF (P=10⁻¹² F)

SERVICE POLICY

Radio Shack's nationwide network of service facilities provides quick, convenient, and reliable repair services for all TANDY/Radio Shack computer products, in most instances. Warranty service will be performed in accordance with Radio Shack's Limited Warranty. Non-warranty service will be provided at reasonable parts and labor costs.

Because of the sensitivity of computer products, and the problems which can result from improper servicing, the following limitations also apply to the services offered by Radio Shack:

1. If any of the warranty seals on any Radio Shack and Tandy computer products it sells are broken, Radio Shack reserves the right to refuse to service the product or to void any remaining warranty on the product.
2. If any computer product purchased from Radio Shack has been modified so that it is not within manufacturer's specifications, including, but not limited to, the installation of any non-Radio Shack parts, components, or replacement boards, then Radio Shack reserves the right to refuse to service the product, void any remaining warranty, remove and replace any non-Radio Shack part found in the product, and perform whatever modifications are necessary to return the product to original factory manufacturer's specifications.
3. The cost for the labor and parts required to return the computer product to original manufacturer's specifications will be charged to the customer in addition to the normal repair charge.

**CUSTOM MANUFACTURED FOR RADIO SHACK
A Division of Tandy Corporation**

**U.S.A.: FORT WORTH, TEXAS 76102
CANADA: BARRIE, ONTARIO L4M 4W5**

TANDY CORPORATION

AUSTRALIA	BELGIUM	FRANCE	U. K.
91 Kurrajong Avenue Mount Druitt. N S W 2770	Rue des Pieds d'Alouette, 39 5140 Naninne (Namur)	Centre Commercial des 3 Fontaines B P. 147 95022 Cergy Pontoise Cedex	Bilston Road Wednesbury West Midlands WS10 7JN